

## Features & Benefits

- Universal AC input voltage(120-277VAC)
- Linear form factor, metal sheet case(white), side feed
- Isolated 0-10v dimming interface, dim down to true 1.05 mA
- Low standby power: <0.7W@120VAC
- Suitable for indoor use
- Flicker free, excellent camera compatibility, spec-grade smoothness
- Class2, Class P
- Comply with IEEE1789, UL8750

### USB programmable feature:

- ◆ Output current, dim to off, min dimming level
- ◆ Otp point of driver, led module thermal protection, luminous decay compensation,
- ◆ End-of-life indicator, fade in time, over load protection point
- ◆ Dimming curve: Log/linear/square dim curves

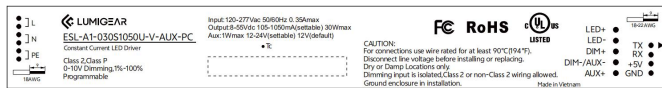

## Model List

Model Name	Rated Input Voltage	Max Output Power(Total)	Output Current(Total)	Rated Output Voltage	Efficiency	Dimension
ESL-A1-030S1050U-V-AUX-PC	120-277VAC	30W max.	105-1050mA	8-55VDC	89%	280*30*21.5 mm 11x1.2x0.8 in.

## Optional Function

Aux power: 12-24V programmable,1W

## Approvals



### Model name code

ESL-A1	=	030S	1050	U	=	V	=	AUX	=	PC
①		②	③	④		⑤		⑥		⑦

①	Series	ESL Series
②	Output power	Maximum output power: 30W
③	Output current(max)	Maximum output current: 1050mA
④	Input voltage	U=120-277VAC M=120-347VAC
⑤	Dimming Control	0-10V
⑥	AUX	AUX: with Auxiliary source BLANK:without Auxiliary source
⑦	Programmable	USB-PC

## Specification:

Parameters	Symbols	Test Conditions / Comment	Min	Typ	Max	Units
------------	---------	---------------------------	-----	-----	-----	-------

### INPUT

Input Voltage	$V_{IN}$		108		305	$V_{AC}$
Rated Input Voltage	$V_{IN\ RATED}$		120		277	$V_{AC}$
Input Frequency	$f_{line}$		47	50/60	63	Hz
Input Current	$I_{IN}$	Full Load, $V_{IN} = 120V_{AC}$			0.35	A
Inrush Current	$I_{INRUSH}$	Cold Start, $V_{IN} = 277V_{AC}$			35	A
Leakage Current	$I_{Leakage}$	$V_{IN} = 277V_{AC}$ 60Hz			0.75	mA

Number of Drivers per MCB(Circuit Breaker)	MCB type	B10	C10	D10	B13	C13	D13	B16	C16	D16	B20	C20	D20
	120V <sub>AC</sub>	19	22	26	25	29	34	31	36	41	39	45	52
	277V <sub>AC</sub>	13	22	44	17	29	58	21	35	71	26	44	89

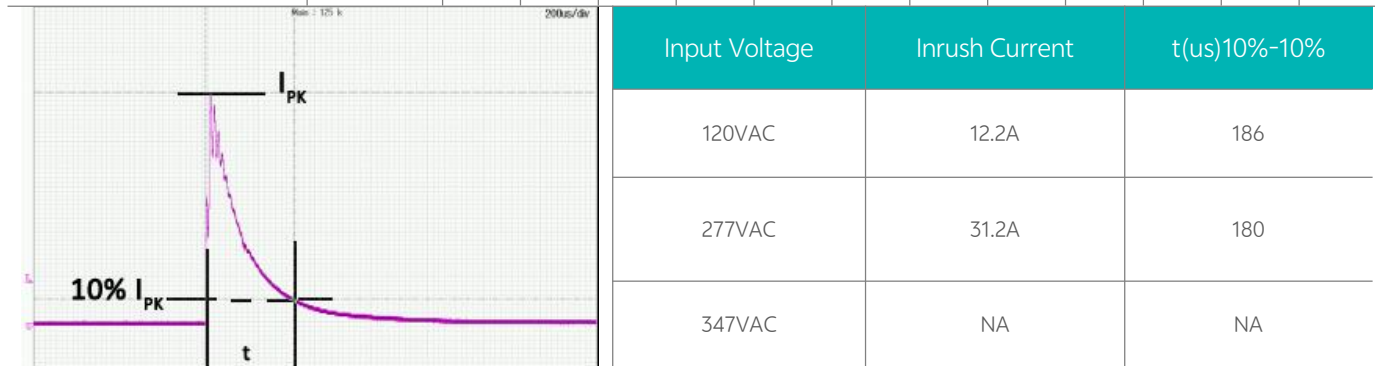

### General Characteristics

Power Factor	PF	35-100% load, $V_{IN} = 120V_{AC}$	0.9		PF
		40-100% load, $V_{IN} = 277V_{AC}$	0.9		
Total Harmonic Distortion	THD	20-100% load, $V_{IN} = 120V_{AC}$		20	%
		40-100% load, $V_{IN} = 277V_{AC}$		20	%
Efficiency	$\eta$	$V_{out}=55V$ , $I_{out}=545mA$ , $V_{IN}=120V_{AC}$ , steady state	85	87	%
		$V_{out}=55V$ , $I_{out}=545mA$ , $V_{IN}=277V_{AC}$ , steady state	87	89	%
Turn On Delay Time	$T_{on\_delay}$	Cold Start, 300-1050mA		0.5	S
		Cold Start, 105-299mA		1	S

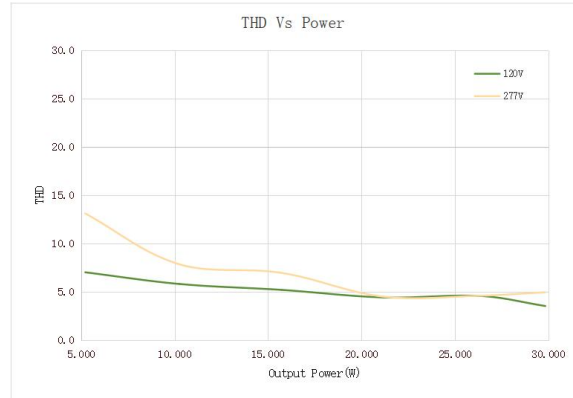
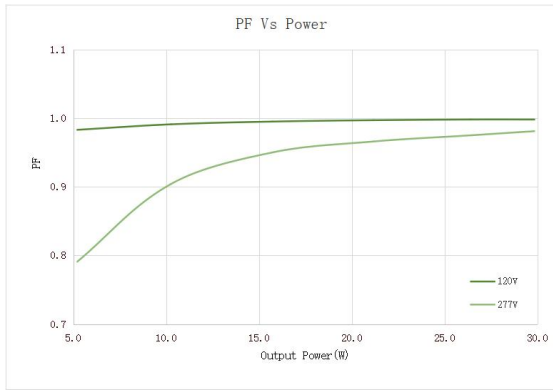

## OUTPUT

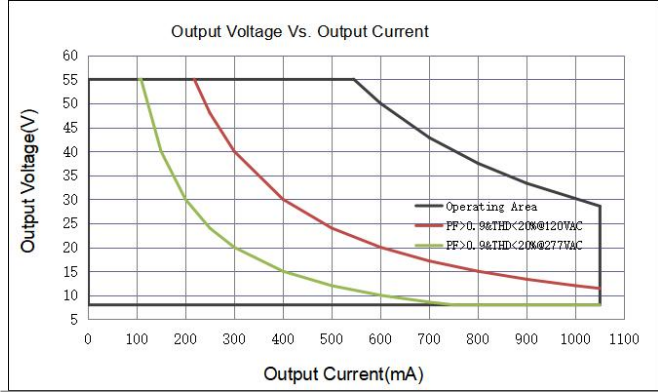
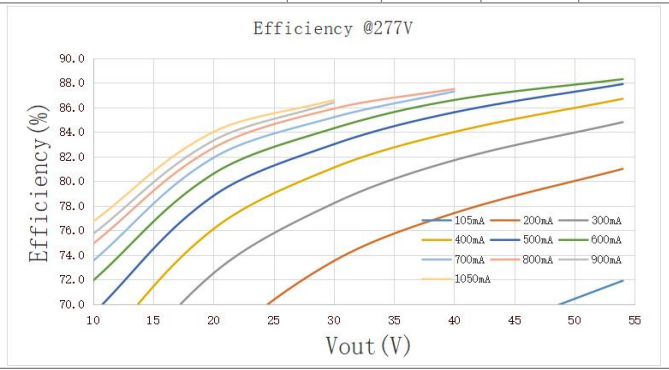
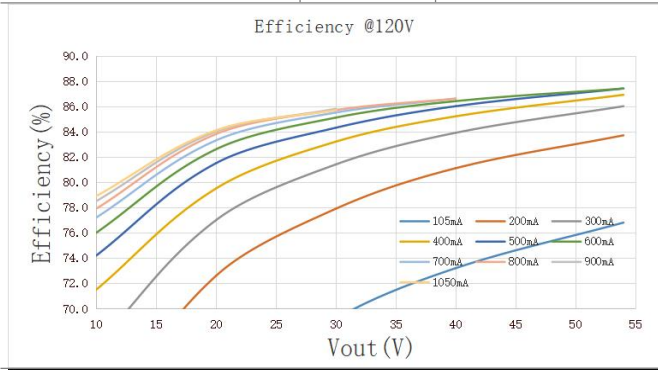

Programmable Current	Output	$I_{OUT}$	Total current	105	1050	mA
Output current tolerance	t		$I_{OUT}=300-1050mA$		5	%
			$I_{OUT}=105-299mA$		7	%
Output Current Range		$I_{OUT}$	Amplitude Control.	1.05	1050	mA
Output Voltage		$V_{OUT}$		8	55	V
Output Power		$P_{OUT}$	See "Operating window"		30	W
Line Regulation		$V_{OUT-LINE}$			3	%
Load Regulation		$I_{OUT-LOAD}$	$V_{OUT}$ from MIN. to MAX.		5	%
Ripple Current		$I_{OUT-RIPPLE}$	Full Load, $(I_{omax}-I_{omin})/(I_{omax}+I_{omin})$ , BW=100KHz		10	%
Output Current Overshoot		$I_{OVERSHOOT}$	Turning Power ON		10	%



## Programming

User can program the driver via terminal block.

- Output current(1mA Step)
- Dim to off
- Min Dimming Level
- OTP point of driver
- LED module thermal protection
- Luminous decay compensation
- End-of-life indicator
- Fade in time
- Over load protection point
- Dimming curve: Log/linear/square

Interface- Terminal block	The terminal block can recognize the type of input signal, analog or digital. So the driver can be easily connected to a digital control system, or can be connected to an external NTC / rheostat / current selection switch to set the driver(eg: output current , dimming curve, and so on).				
	Programming software	“LUMIGEAR Programming Tool”			
	Programming tool	“Lumigear tool box”			
	Operating voltage		5	5.5	V
	Pull up resistor	TX/RX are pulled up to +5V	62K		Ohm
	+5V Aux power			10	mA
Programming Interface	PGT-USB-TPAC-A				
Programming Cables	PGT-USB-P254				

## 0~10V or Resistor Dimming

The 0~10V or resistor dimming can be used to dim the output Current via a standard commercial wall dimmer (0~10V<sub>DC</sub>) or an external control voltage source (0~10V<sub>DC</sub>) or external resistor.

Dimming Curve	Linear. please see “Dimming curve”.				
Absolute Maximum Voltage on 0~10V Pin	V <sub>DIM</sub>		0	300	V
Source Current on 0~10V Dimming Pin	I <sub>DIM</sub>		200		uA
Light On	V <sub>DIM-on</sub>	Programmable		0.9	V
Light Off	V <sub>DIM-off</sub>	Programmable		0.7	V
Clamp Voltage	V <sub>DIM-Clamp</sub>	Programmable		1	V
Dimming Voltage for Full Bright	V <sub>DIM-MAX</sub>	Programmable		8	V
Leakage Voltage	V <sub>Leak_rms</sub>	Voltage between DIM- and Ground		20	V <sub>AC</sub>
Standby power	P <sub>STANDBY</sub>	Light Off, V <sub>IN</sub> =120V		0.7	W

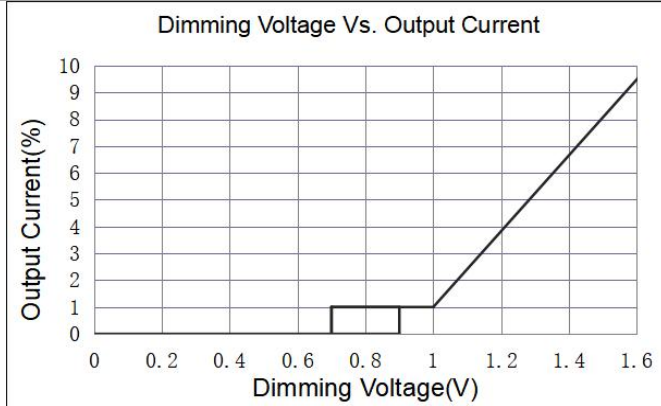
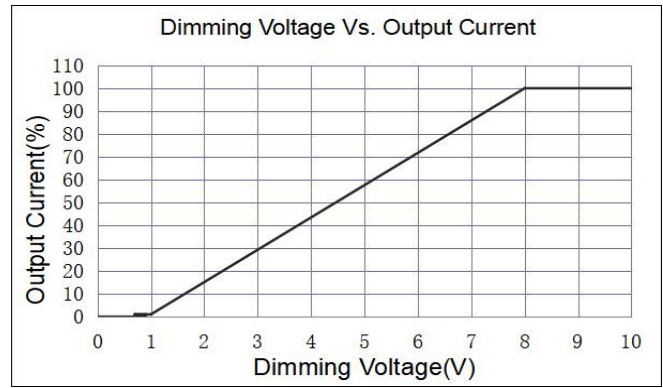
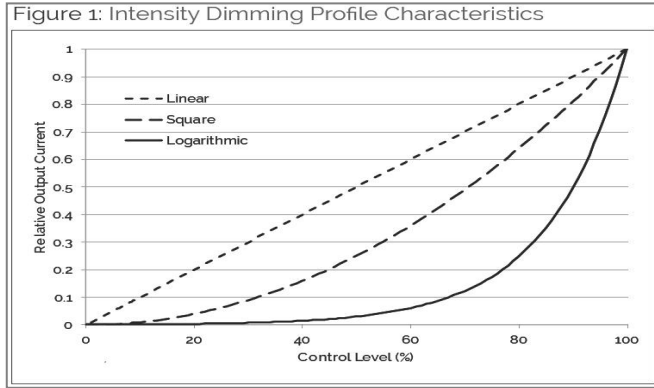

### Auxiliary source (Optional)

Max.power	$P_{AUX}$			1	W
Voltage range	$V_{AUX}$	Programmable	12	24	Vdc
	$V_{AUX\_DEFAULT}$	Default voltage		12	Vdc
Voltage tolerance	$t_{AUX}$			8	%
Over load Protection	$P_{OLP\_AUX}$	Foldback mode		1.5	W

### LED Thermal Protection (NTC) Characteristic

The LED thermal protection feature of the driver helps reduce the temperature of the LED module by reducing dual output current together in case of abnormal temperature conditions.

In the end application, care must be taken to place the NTC thermistor close to the hottest spot on the LED module.

If LED thermal protection is not required the NTC port on the LED power supply connector can be left open.

Graphs for reference. The derating limits can be programmed using the Light Touch.

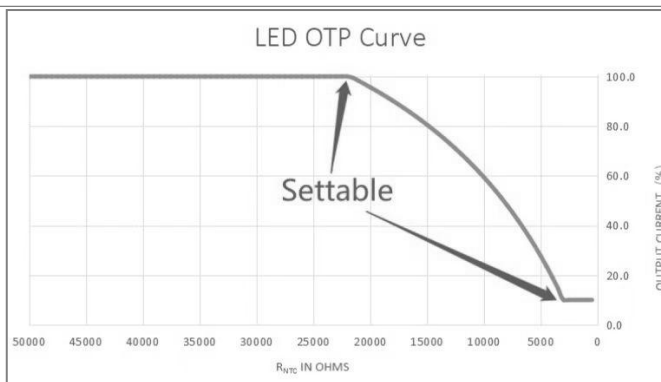

## Protection

Over Voltage Protection	$V_{OVP}$	Recover automatically after fault conditions is removed.			60	V
Over load protection	$P_{OLP}$	Programmable. The output current will decrease when output power reach $P_{OLP}$	12		30	W
OLP tolerance	$t_{OLP}$		100		110	%
Over Temp. Protection	$T_{OTP}$	Programmable. Current foldback at hotspot greater than $T_{OTP}$		90		°C
Short Circuit Protection	The unit will recover automatically after fault conditions is removed.					

## Environment

Storage Temperature	$T_{Storage}$	Humidity: 5% RH to 95% RH	-40	-	+85	°C
Ambient Operating Temperature	$T_a$		-30	-	+50	°C
Max. Case Temperature	$T_c$	Hot spot on case			90	°C
Operating Relative Humidity	$H_a$	Non-Condensing	10		90	%
Acoustic Noise		Measured from 1 m w/o dimmer.			24	dBA
Cooling	Convection Cooling					
IP Rating	Dry and damp UL approved					

## Others

Life Time	$T_{Life}$	Full Load, 80°C case temperature, $V_{IN} = 120/277V_{AC}$	50			kHrs
MTBF	$T_{MTBF}$	Full Load, 25°C ambient temperature $V_{IN} = 120/277V_{AC}$	200			kHrs
Net Weight	$W_{NET}$			205		g
Warranty	5 Years Warranty at $T_c \leq 80^\circ C$					
Flicker	IEEE 1789, Title 24					

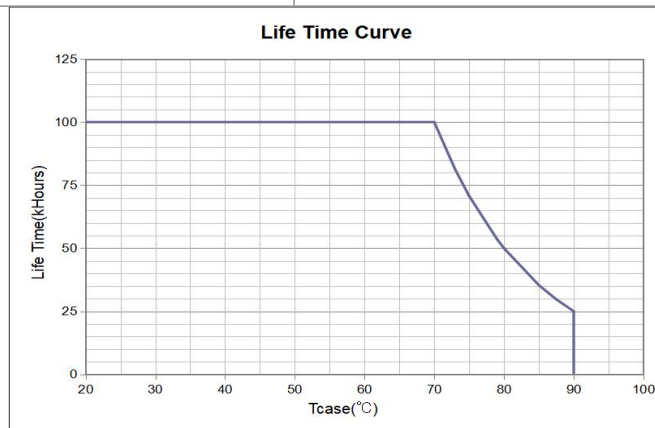

## Safety Compliance

CUL/UL	UL8750, CAN/CSA-C22.2 No. 250.13
--------	----------------------------------

## Electromagnetic Compliance

EMC Requirements	Standard	Conditions
------------------	----------	------------

EMI Emissions	FCC Title 47 Part 15B	Class B at 120V <sub>AC</sub> , Class A at 277V <sub>AC</sub>
Voltage Fluctuations and Flicker	IEC61000-3-3	
Immunity Compliance	IEC 61000-4-2	±8kV air Discharge, ±6kV Contact Discharge
	ANSI C62.41-2002	± 2kV Common and Differential Mode, test at 2 Ω, 5 strikes/1minute interval (40 total strikes)
	ANSI C62.41.1-2002	2.5kV Ring Wave, test at 30Ω 7 Strikes/1 minute interval, Common and Differential mode, 56 total strikes
	IEC 61000-4-11	>95% dip, .5 period; 30% dip, 25 periods; 95% reduction, 250 periods
	IEC 61000-4-4	± 2kV Direct couple to Line input, 5kHz repetition rate, 15mS duration, 300mS period. 7 coupling paths, 1 minute per path (14 total combinations)

Note: Unless otherwise specified, all the above parameters are measured at ambient temperature of 25°C and rated voltage.

## Typical Application

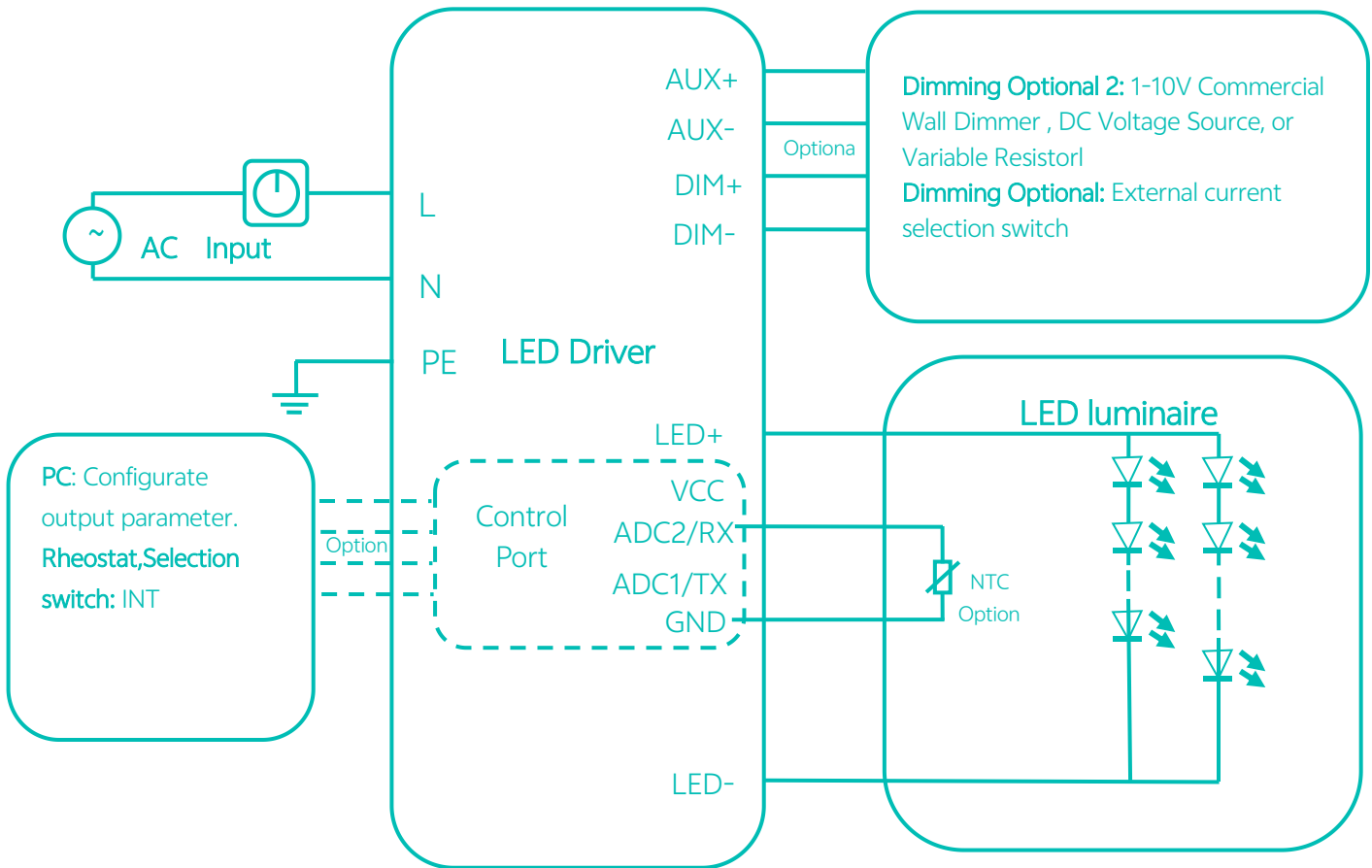

## Packaging

Driver quantity (pcs)	Layer	Weight (kg)	Outer dimensions of Carton L*W*H(mm)
63	7	14	330 X 300 X 230

## Mechanical Drawing:

