

Features & Benefits

- Universal ac input voltage(120-277VAC)
- Field installation
- Dry, damp and wet location design, IP66
- Built-in APFC
- Isolated 0-10v dimming, dim down to 5%
- Complies with leading-edge/trailing-edge dimmer
- Wide load range from 5w to 36w(triac dimming)
- All-round protection: SCP, OVP, OTP, OPP
- Constant voltage PWM style output
- Class2
- Operating temperature: -25°C~+65°C
- Comply with title24, UL8750

Model List

Model Name	Rated Input Voltage	Max Output Power(Total)	Output Current(Total)	Rated Output Voltage	Efficiency	Dimension
CVJ-A1-036S024X-VT	120-277VAC 120-347VAC	36W max.	0-1500mA	24VDC	85%	152.6*67.6*35.8 mm 6*2.6*1.4 in.

Optional Function

Input voltage: 120-277VAC or 120-347VAC

Approvals

TRIAC

0/1-10 V



Model name code

CVJ-A1	=	036S	024	X	=	VT
①		②	③	④		⑤

①	Series	CVJ Series
②	Output power	Maximum output power: 36W
③	Output Voltage	Output voltage:24V
④	Input voltage	U=120-277VAC M=120-347VAC
⑤	Dimming Control	Triac&0-10V

Specification:

Parameters	Symbols	Test Conditions / Comment	Min	Typ	Max	Units							
INPUT													
Input Voltage	V_{IN}		108		305	V_{AC}							
Rated Input Voltage	$V_{IN,RATED}$		120		277	V_{AC}							
Input Frequency	f_{line}		47	50/60	63	Hz							
Input Current	$I_{IN,120}$	Full Load, $V_{IN} = 120V_{AC}$			0.4	A							
	$I_{IN,277}$	Full Load, $V_{IN} = 277V_{AC}$			0.18	A							
Inrush Current	I_{INRUSH}	Cold Start, $V_{IN} = 277V_{AC}$			50	A							
Leakage Current	$I_{Leakage}$	$V_{IN} = 277V_{AC}, 60Hz$			0.75	mA							
Number of Drivers per MCB(Circuit Breaker)	MCB type	B10	C10	D10	B13	C13	D13	B16	C16	D16	B20	C20	D20
	120V _{AC}	12	17	19	15	22	25	19	27	31	24	34	39
	277V _{AC}	7	11	23	9	15	30	11	18	37	14	23	47

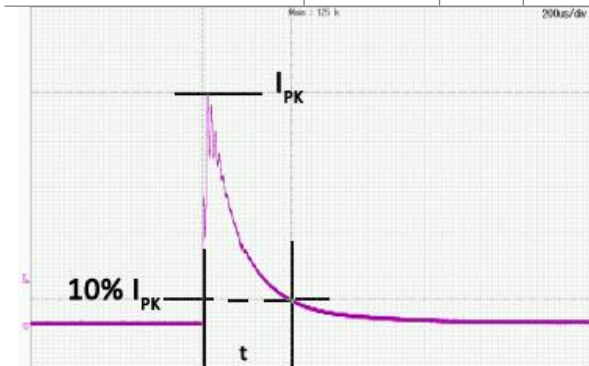

Input Voltage	Inrush Current	t(us)10%-10%
120VAC	17.1A	192
277VAC	34A	216

General Characteristics

Power Factor	PF	30-100% load, $V_{IN} = 120V_{AC}$	0.9			PF
		70~100% load, $V_{IN} = 277V_{AC}$	0.9			
Total Harmonic Distortion	THD	30-100% load, $V_{IN} = 120V_{AC}$			20	%
		70~100% load, $V_{IN} = 277V_{AC}$			20	
Efficiency	η	Full load, $V_{IN} = 120V_{AC}$	82	84		%
		Full load, $V_{IN} = 277V_{AC}$	83	84		
Turn On Delay Time	$T_{on, delay}$	Cold Start		0.3	0.5	S

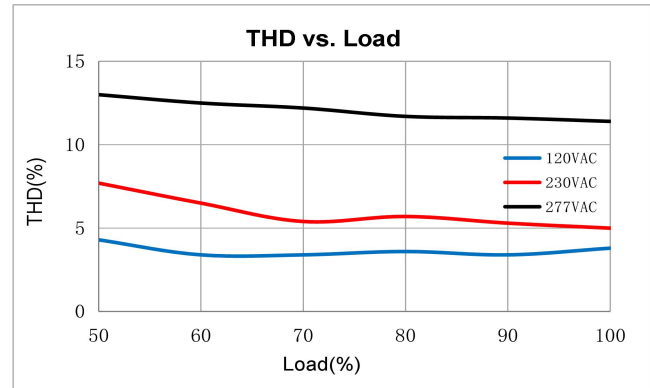
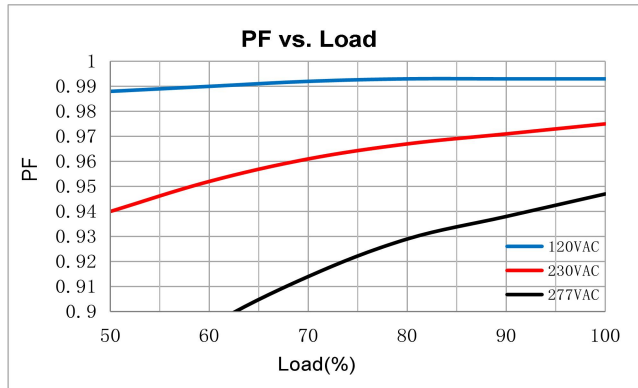

OUTPUT

Output Voltage Tolerance	t_{OUT}	No Dimming			5	%
No Load Output Voltage Tolerance	$t_{NO\ LOAD}$	No Load, No Dimming			5	%
Output Current	I_{OUT}		0		1500	mA
Output Power	P_{OUT}				36	W
Line Regulation	$V_{OUT-LINE}$				5	%
Ripple Voltage	$V_{OUT-LINE}$	Full Load, (pk-to-pk)/Average			10	%
Output Voltage Overshoot	$V_{OVERSHOOT}$	Turning Power ON			10	%

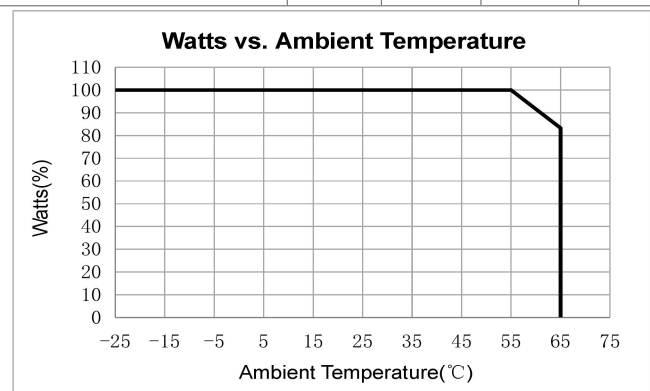
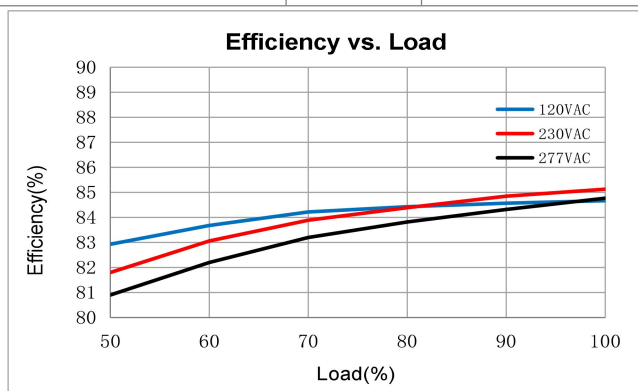

0~10V or Resistor Dimming

The 0~10V or resistor dimming can be used to dim the output voltage via a standard commercial wall dimmer (0~10VDC) or an external control voltage source (0~10VDC) or external resistor. The unit can be compatible with both sink and source current dimmers.

Dimming Curve	Linear. please see "Dimming curve".					
Absolute Maximum Voltage on 0~10V Pin	V_{DIM}		0		15	V
Source Current on 0~10V Dimming Pin	I_{DIM}			100		uA
Dimming Voltage for Full Bright	$V_{DIM-MAX}$		8			V

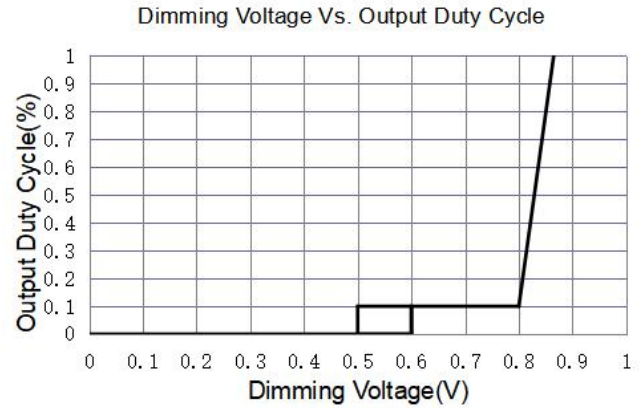
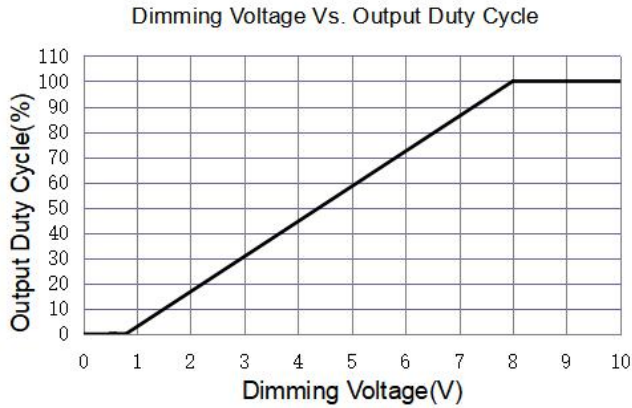

Triac Dimming

The unit is compatible With Leading-edge and Trailing-edge Dimmer.

Input Voltage	$V_{IN-TRIAC DIM}$			120		V_{AC}
Dim Output Voltage	$V_{OUT-TRIAC}$	PWM Output	0.1	-	100	% of V_{OUT}
Suggest Load Range	$P_{Suggest}$	$V_{IN} = 120 V_{AC}$	5		36	W

Protection

Over Voltage Protection	V_{OVP}	Latch mode.	26		30	V
Over Power Protection	P_{OPP}	Hiccup mode.	36		50	W
Over Temperature Protection	T_{OTP}	If the case temperature exceeds OTP point, the output voltage of the driver is automatically reduced.	100	105	110	°C
Short Circuit Protection	The unit can recover automatically after fault conditions is removed.					

Environment

Storage Temperature	$T_{Storage}$	Humidity: 5% RH to 95% RH	-40	-	+85	°C
Ambient Operating Temperature	T_a		-25	-	+65	°C
Max. Case Temperature	T_c	Hot spot on case			88	°C
Operating Relative Humidity	H_a	Non-Condensing	10		90	%
Acoustic Noise		Measured from 1 m w/o dimmer.			24	dBA
Cooling	Convection Cooling					
IP Rating	IP66					

Others

Life Time	T_{Life}	Full Load, 80°C case temperature,	50			kHrs
MTBF	T_{MTBF}	Full Load, 25°C ambient temperature	200			kHrs
Warranty	5 Years Warranty at $T_c \leq 80^\circ C$					

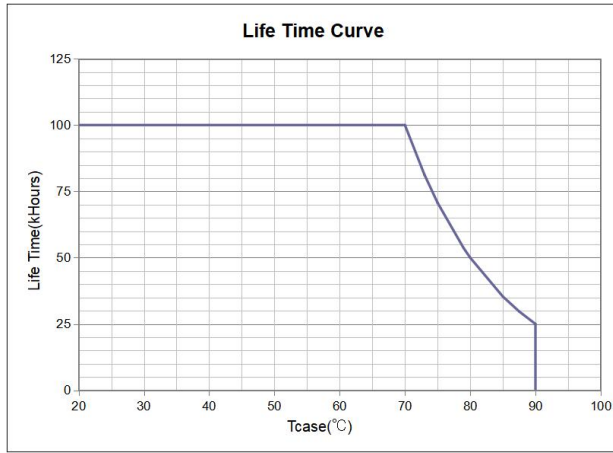

Safety Compliance

CUL/UL	UL8750, CAN/CSA-C22.2 No. 250.13
--------	----------------------------------

Electromagnetic Compliance

EMC Requirements	Standard	Conditions
EMI Emissions	FCC Title 47 Part 15B	Class B at 120VAC, Class A at 277VAC
Voltage Fluctuations and Flicker	IEC61000-3-3	
Immunity Compliance	IEC 61000-4-2	±8kV air Discharge, ±6kV Contact Discharge
	IEC 61000-4-5 or ANSI/IEEE C62.41-2002	± 4kV Common Mode(12 Ω), ± 2kV Differential Mode(2 Ω), 5 strikes/1minute interval (40 total strikes)
	ANSI/IEEE C62.41.1-2002	2.5kV Ring Wave, test at 30Ω 7 Strikes/1 minute interval, Common and Differential mode, 56 total strikes
	IEC 61000-4-11	>95% dip, .5 period; 30% dip, 25 periods; 95% reduction, 250 periods
	IEC 61000-4-4	± 2kV Direct couple to Line input, 5kHz repetition rate, 15mS duration, 300mS period. 7 coupling paths, 1 minute per path (14 total combinations)

Note: Unless otherwise specified, all the above parameters are measured at ambient temperature of 25°C and rated voltage.

Typical Application

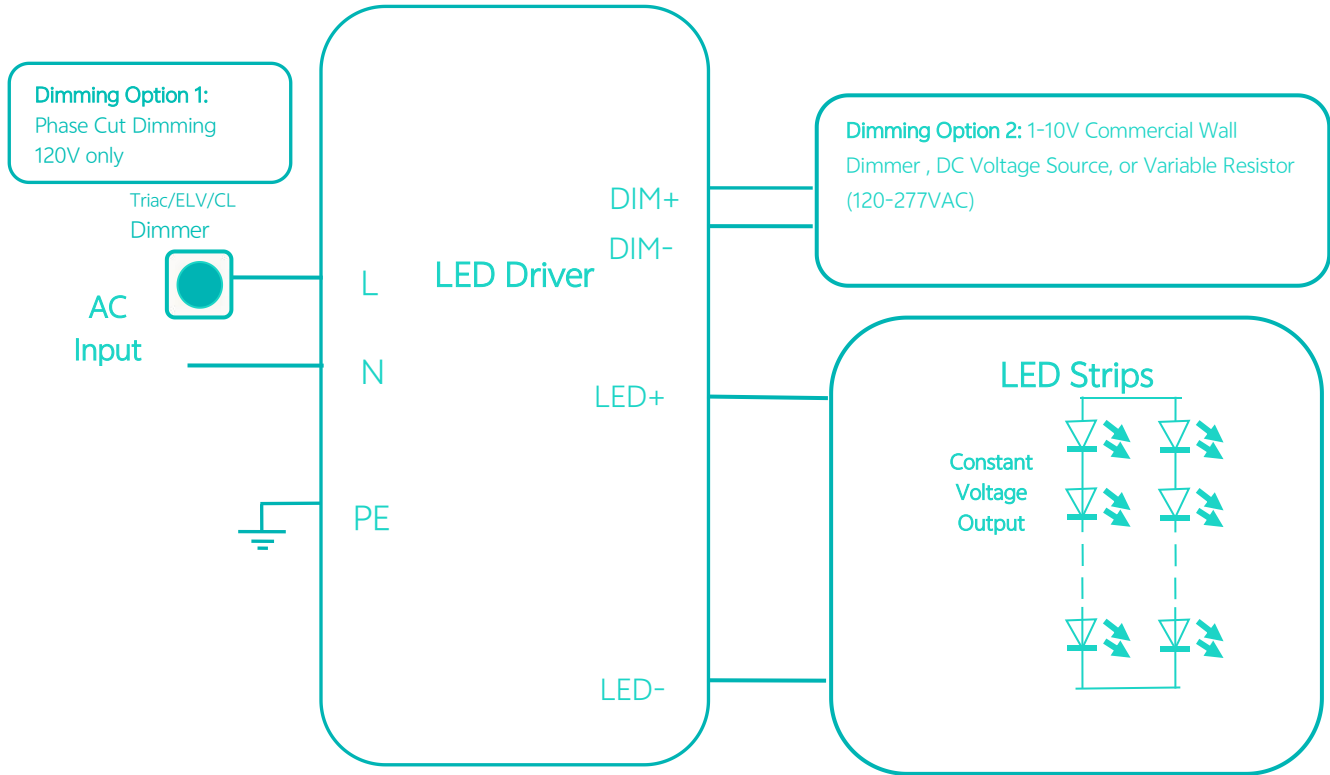

Fig. Typical Application

Packaging

Driver quantity (pcs)	Layer	Weight (kg)	Outer dimensions of Carton L*W*H(mm)
TBD			330 X 305 X 210

Mechanical Drawing:

